

S1-Pro User Manual

V1.0



Skydroid Co.,Ltd

Suggestion: When you read this user manual, operate it at the same time. When you read these instructions, if you encounter difficulties, please refer to this user manual or call our after-sales service (400-6996-520) or visit our WeChat public platform, also, you can visit our official QQ chat group: 318480806 to view related questions and answers.



Skydroid official QQ chat group



Skydroid WeChat public platform

After-sales service terms

1. These terms are only applicable to the products produced by Skydroid Co., Ltd., and the products sold by authorized Skydroid distributors are also applicable to this clause.
2. From the date of purchase, our company has verified that the quality problems are not caused by human beings within one week, and Skydroid will afford the round-trip express fee for the repaired products. If you purchase Skydroid products more than one week, the quality will be verified by our company within one year. If there is any problem, the user and Skydroid each affords the courier fee for sending the repaired product.
3. Proof of purchase and warranty card or online platform transaction records are required when returning for repair.
4. Skydroid products have quality problems that are not caused by human beings under normal use within seven days from the date of purchase, and the appearance is not damaged. With the warranty card and purchase proof, you can negotiate with the dealer for a free replacement of the same model product; Once the dealer receives the replacement product, please notify Skydroid company for the record and replacement at the first time.
5. Skydroid products will be provided lifelong after-sales service by us. Quality problems that are not caused by human beings will be guaranteed for one year free of charge; for artificial damage, modification, disassembly and more than one year free warranty from the date of purchase. The user shall pay the round-trip postage and maintenance costs.
6. In order to ensure that your rights and interests are protected and to serve you in a timely and effective manner, please complete the warranty card and ask for the purchase proof when purchasing Skydroid products. To enjoy this after-sale service, users shall provide warranty card and purchase proof.
7. The repaired product will be returned to the customer within 15 working days after receipt by Skydroid, and the repair report will be attached.
8. The above after-sales service terms are limited to Skydroid products sold in China mainland.

After-sales questions from Hong Kong, Macao, Taiwan and overseas customers, please send to sales01@skydroid.xin, and the specific after-sales details will depend on the situation.

Content

Content	1
1、 Overview of S1-PRO	2
1.1、 Components	2
1.2、 Ports and Technical Parameters	2
1.3、 Recommendations for use	5
2、 Overview of the remote controller	5
2.1、 Remote control (Mode 2)	5
2.2、 Overview of the remote control functions	6
2.3、 Remote controller charging	6
2.4、 Remote control antenna angle	7
3、 Skydroid Fly APP	8
3.1、 Use Skydroid Fly APP	8
3.2、 App main interface	8
4、 Preparation for the first use	9
4.1、 Rack Type Selection	9
4.2、 Flight control monitoring	10
4.3、 RTK antenna settings	10
4.4、 Horizontal calibration	11
4.5、 Compass calibration	11
4.6、 ESC calibration	12
4.7、 Motor testing	12
4.8、 Basic Settings	13
4.8.1、 Attitude Setting	13
4.8.2、 Navigation Settings	13
4.8.3、 Speed Setting	14
4.8.4、 Power setting	14
4.9、 Other Settings	15
4.10、 Auxiliary settings	15
4.11、 Introduction of airplane modes	16
4.12、 Use of laser obstacle avoidance module	17
5、 Out of control protection	17
6、 Hardware installation	18
6.1、 Install S1-PRO on the drone	18
6.2、 Connect flight control to your multi axis system	19
6.2.1、 Selection of motor steering sequence	19
6.2.2、 Identification of clockwise and counterclockwise propellers	20
6.2.3、 Accessory connection	20
6.2.4、 Installation of Webcam	21
6.3、 Basic flying	22
6.4、 Geo-fence	23
7、 Log download and checking	23
8、 FAQ	24
Exemptions	
Suggestions	

1、 Overview of S1-PRO

1.1、 Components



H12 PRO remote control



S1-PRO



GPS(Optional)



MK43(Optional)



Directional set(Optional)



Whip antenna(Optional)



Flat antenna(Optional)



C10(Optional)



3 in 1 camera network interface version(Optional)



Charger

1.2、 Ports and Technical Parameters

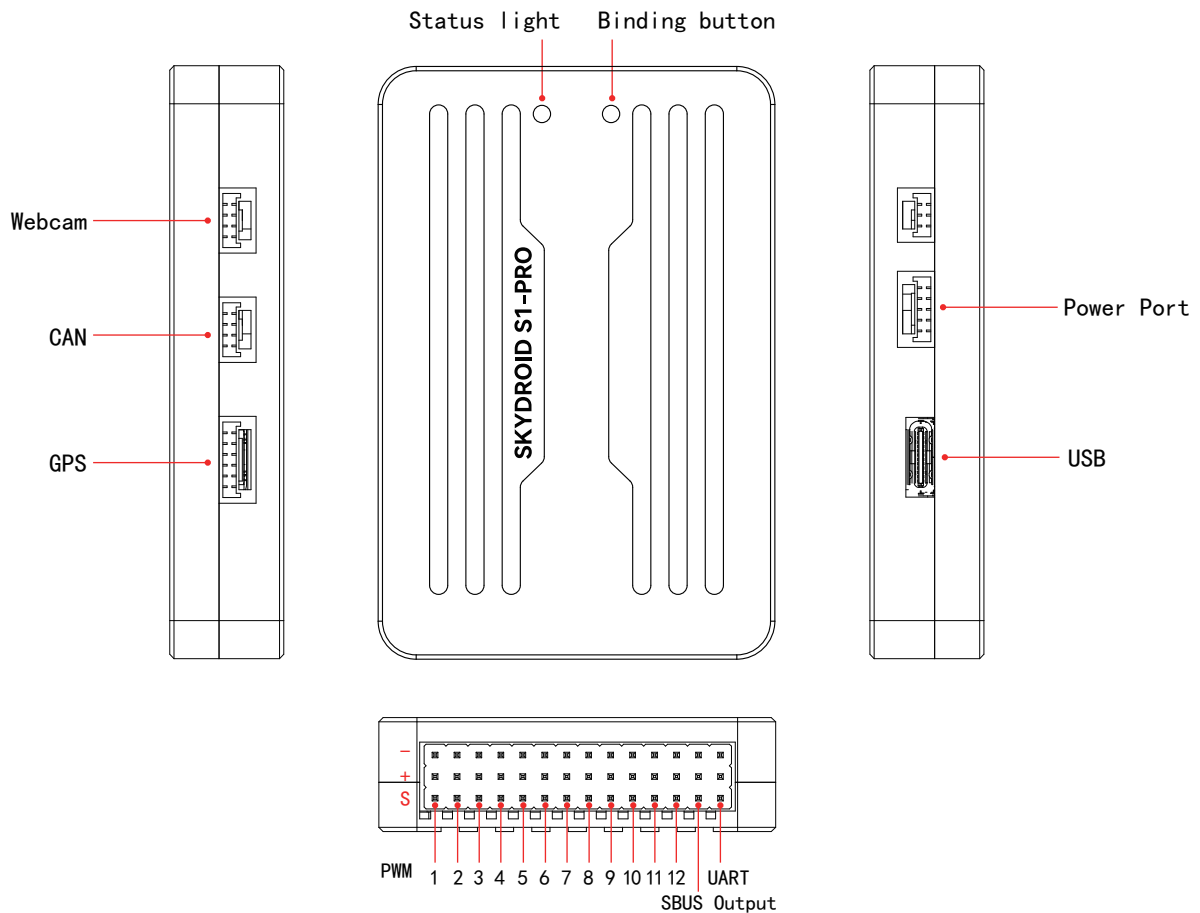

S1-PRO ECS		
Technical Parameters		
Hardware	Processor	STM32F407
	Gyro	BMI088
	Electronic compass	IST8310
	Barometer	LPS22HB
	Interface	GH1.25
	Whip antenna	30cm/40cm/50cm Optional
	PWM Output	12 OneShot/PWM Output(configurable)
	Receiver	Built-in R12 PRO
	Receiver Antenna Gain	4dBm
	Receiver Transmit Power	17.5dBm
	GPS	M10
	RC OUT SBUS	1
	GPS UART Serial Port	1
	Power Port	1
	LAN Port	1
	CAN Port	1
Supported models	3~8 Axes	
Working environment and physical parameters	Power Input Voltage	2s-18s
	USB Voltage	5V±0.3V
	Servo Voltage	5V±0.3V
	Working Temperature	-40~80°C
Size & weight	Size	68*47*13mm
	Weight	62g

C10	
Product name	C10
Input power	7.2V~72V DC
Operating current	210mA
Working temperature	-10°C~+60°C
Weight	61g
Overall dimension (L, W, H)	51mm*43.3mm*61.7mm
Pitch angle	-90°~+10°
Pointing axis angle	-90°~+90°
Rolling angle	45°
Pixel	Effective pixel:400W
Lens specification	1/2.7 sensor EFL=2.4mm
Output mode	RTSP code stream H265, compatible with H264
Image transmission resolution	1080P
Video recording storage resolution	2K
Video storage format	H264 (can be played with the PotPlayer player or other players supporting H264 format)
Photo storage resolution	2K
Photo storage format	JPEG
Working mode	Hoist mode (factory default)
	Upside down mode (self setting)
One click back	support
One click down	support
One button head up	support
Supported memory card types	Currently, only the standard Sandisk 16G memory card and Kingston 64G Class 10 Micro SD card are supported
Support file system	FAT32

1.3、 Recommendations for use

For users who are using the S1-PRO flight controller for the first time, it is recommended to complete the introductory use of the flight controller in steps:

1. First install the ground station control app, and be familiar with the various menu functions of it;
2. Assemble the drone and complete the assembly of the power system;
3. Connect the remote controller to the flight controller to complete compass calibration and motor calibration;
4. Check various parameter settings;
5. Unlock and take off for the first time;
6. Various high-end applications of flight control, auxiliary channel settings.

2、 Overview of the remote controller

2.1、 Remote control (Mode 2)

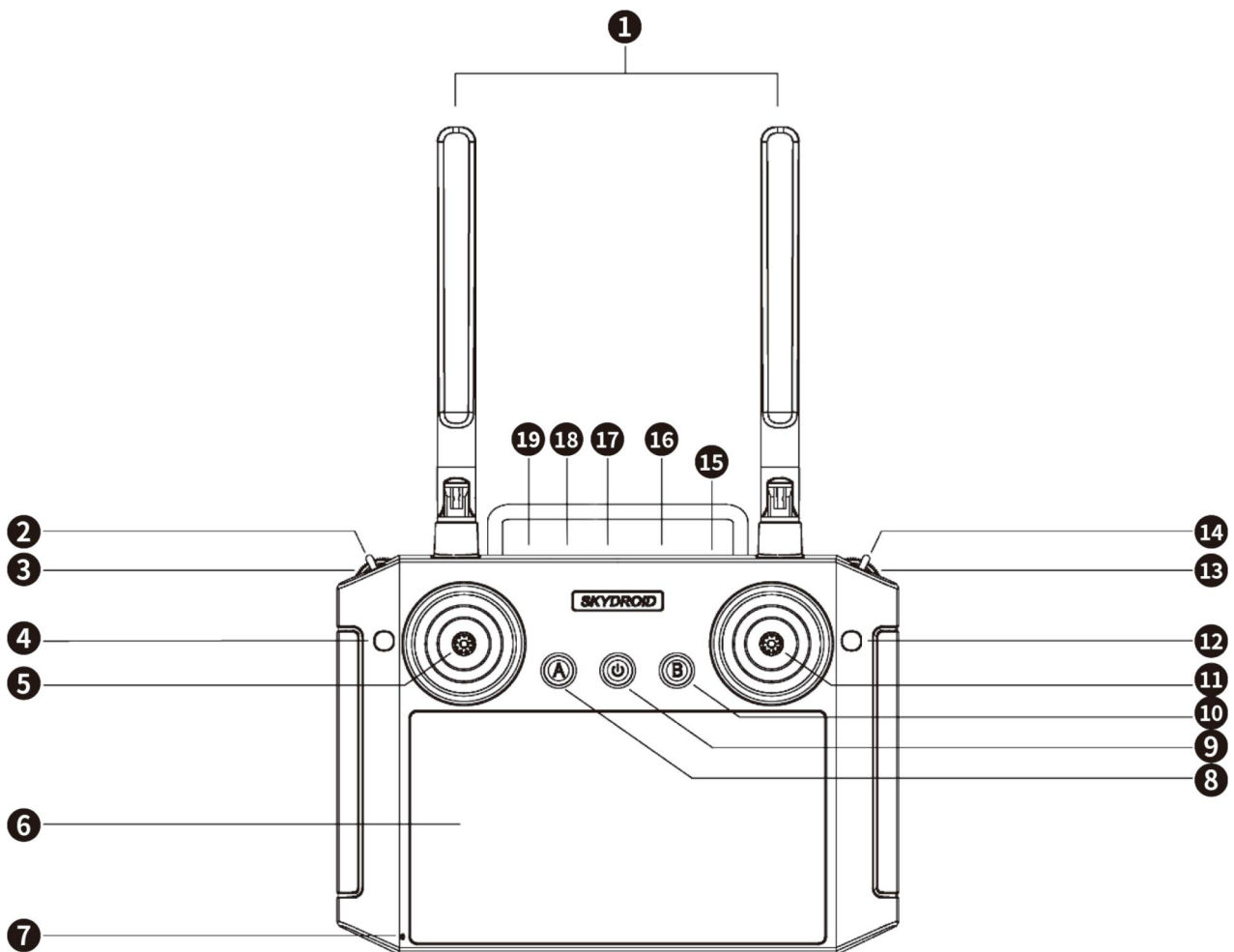

No.	Annotation	No.	Annotation
①	2.4G 4dBm antenna	⑪	Right side Stick X2、 Y2
②	Toggle 3 positions switcher/ Flying mode	⑫	Button D (No function)
③	Thumbwheel switch G (No function)	⑬	Thumbwheel switch H (No function)
④	Button C (No function)	⑭	Toggle 3 positions switcher (No function)
⑤	Left side Stick X1、 Y1	⑮	Dust-free plug
⑥	screen	⑯	SIM card slot
⑦	MIC port	⑰	Charging port
⑧	Button A (No function)	⑱	LAN
⑨	Power switcher		PPM output/ Serial cable port
⑩	Button B (No function)		

2.2、 Overview of the remote control functions

No.	Buttons	Functions description
⑤	Throttle/steering control lever (American mode)	-Push the joystick up and the drone rises. -Pull down the control stick and descend the drone. -Turn the control stick to the left, and the drone rotates to the left.
⑪	Forward/backward/ side fly control lever (American mode)	-Push the joystick up and the drone will move forward. -Pull down the control stick and make the drone back. -Press the control stick to the left, and the drone flies to the left side.
②	Flying mode control	-Fixed height mode -GPS mode -Return home mode

2.3、 Remote controller charging

The remote control is charged with a Type-C USB data cable, please see the No. 17 mark. The charging time of the remote control is about 2-4 hours. The power-on icon of the remote control flashes when charging, and the icon goes out when it is fully charged. The use time is around 5-8 hours after being fully charged.

2.4、 Remote control antenna angle

- (1) Adjust the angle of the remote control antenna to face the drone's flight direction as much as possible;
- (2) Antennas should not obstruct or cross with each other.

Correct operation

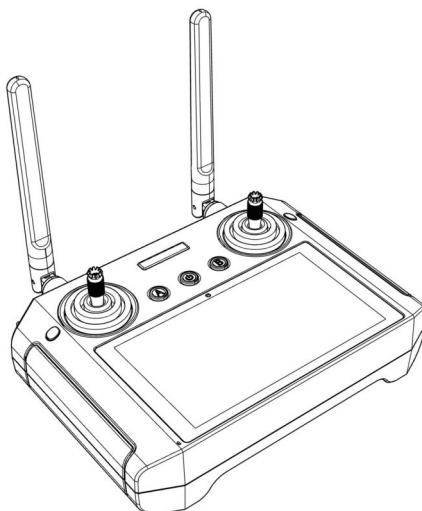

Unfold the antenna and vertically upwards

Wrong operation

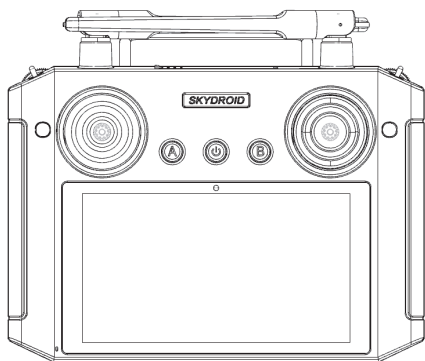

Antennas cannot cross

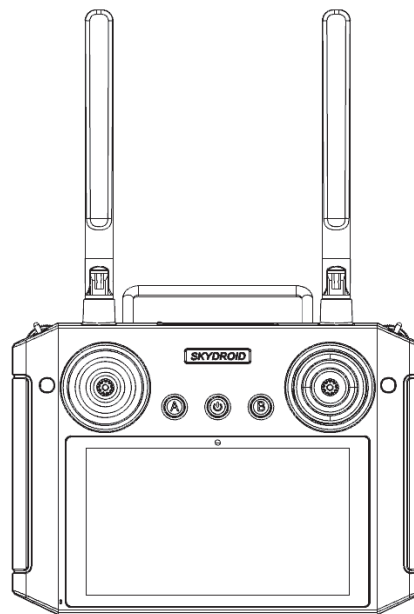

The antenna cannot be parallel to the remote control

3. Skydroid Fly APP

3.1、 Please use Skydroid Fly APP, you can download by scanning the QR code from the card in the package or from our official website: www.skydroid.xin

3.2、 App main interface

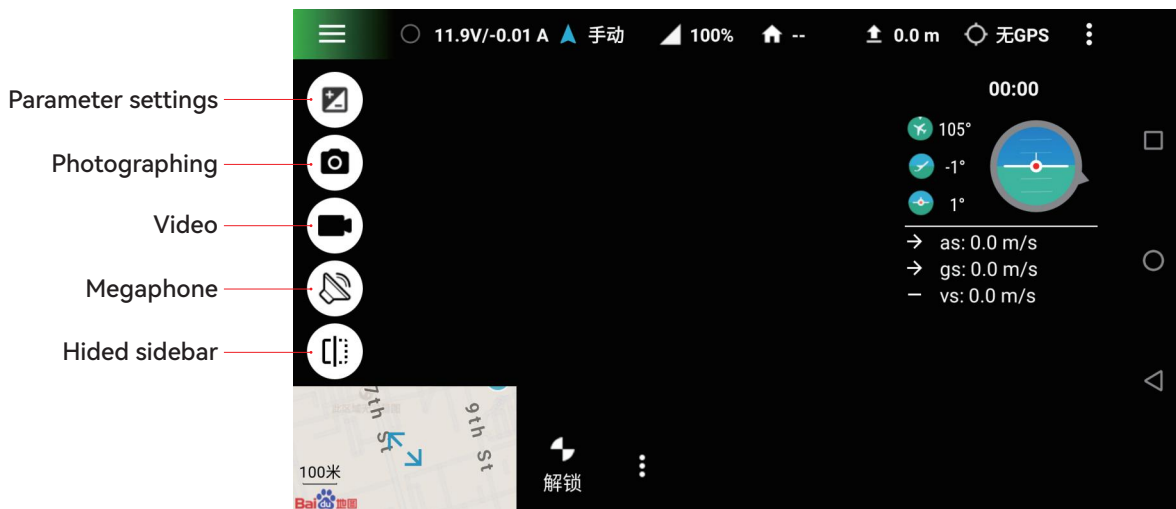

4. Preparation for the first use

Pairing and binding

- ① Power on the S1Pro, and the binding indicator light is constantly red and the green light flashing slowly;
- ② Wait for about 30 seconds after powering on, press and hold the frequency binding button until the green light flashes quickly;
- ③ Open the H12Pro assistant app, click on “frequency binding”, and wait for the screen to show successful frequency binding;
- ④ The frequency binding indicator light will continue to flash for around two minutes and then the green light keeps on.

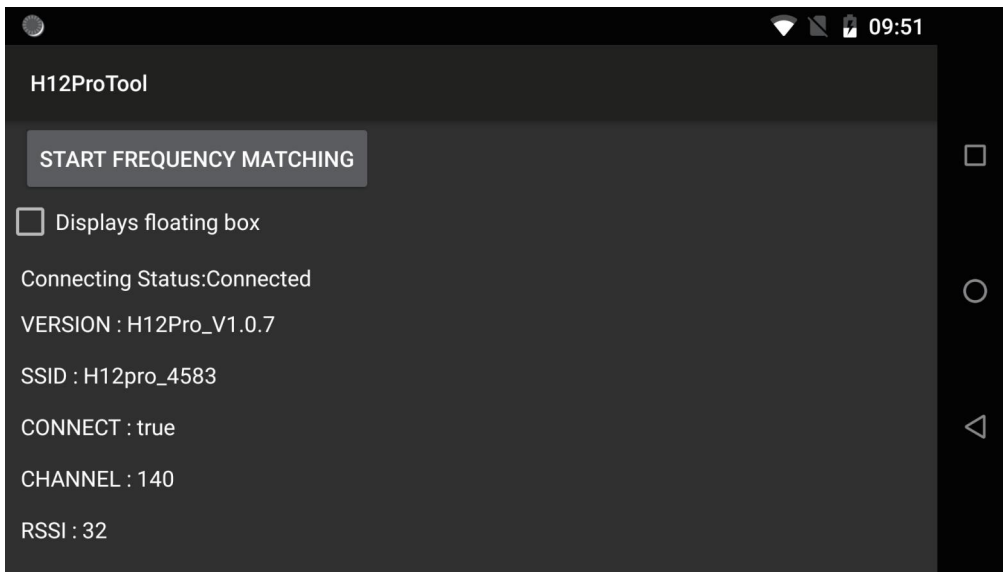

4.1. Rack Type Selection

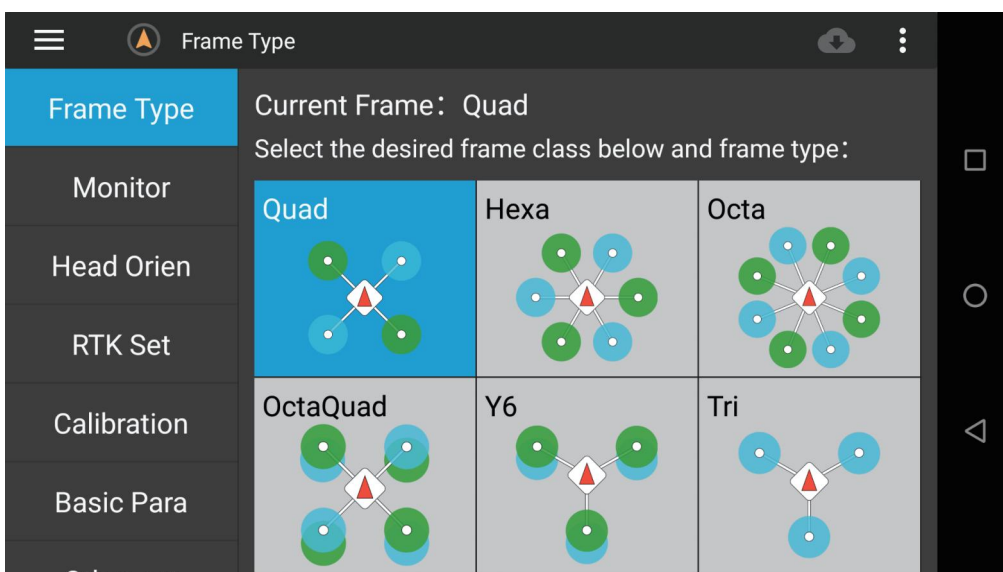

Quad, hexa, octa, Y6 axis, and triple axis, click on the pattern to save the rack type.

4.2. Flight control monitoring

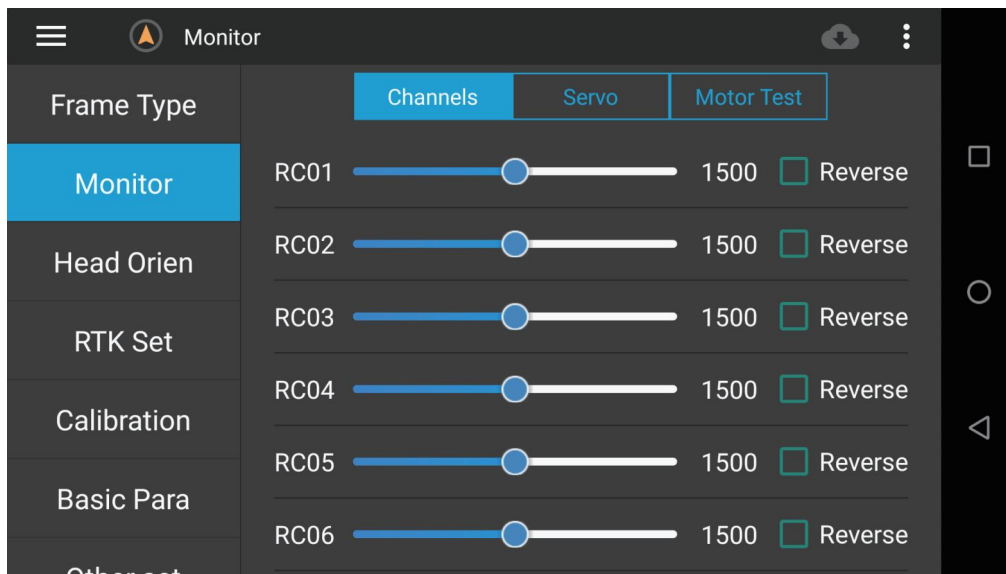

Channel check: Input the rudder value into the remote control channel.
Output check: PWM channel output rudder value of S1Pro.

4.3. RTK antenna settings

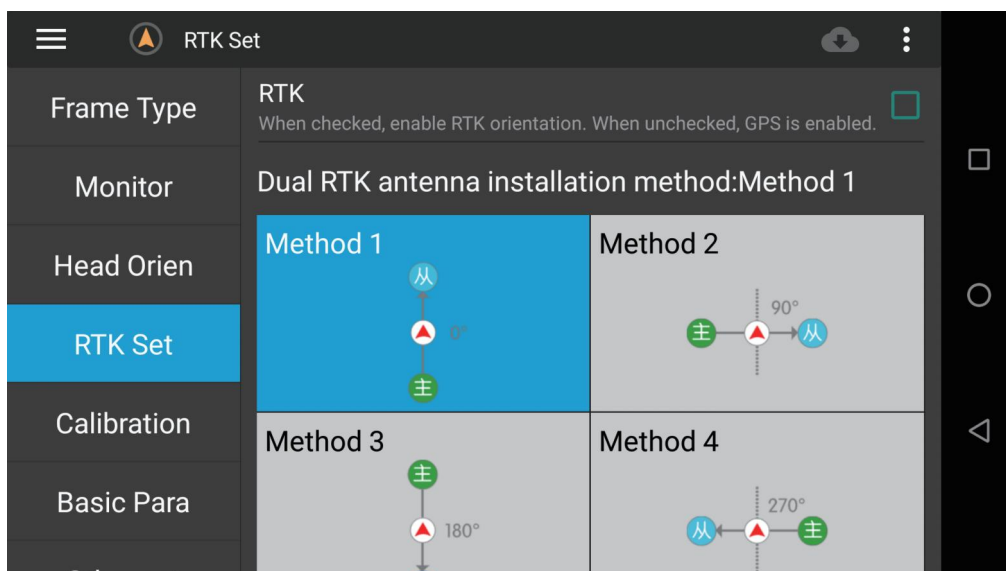

Choose when using the RTK antenna, and do not choose when using the GPS antenna.
(Check the purchased item is a RTK version or not)

4.4. Horizontal calibration

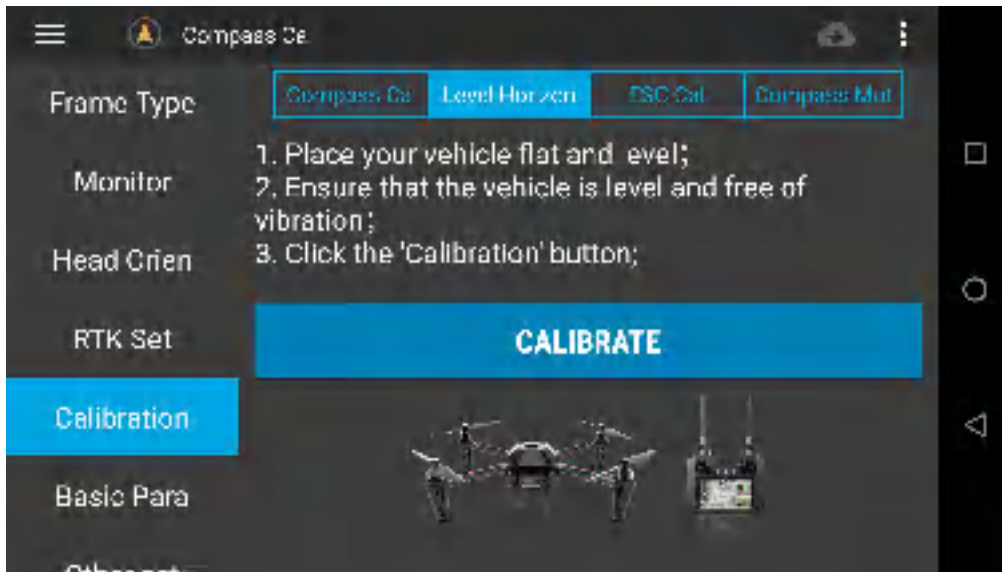

Step 1: Place the drone on a flat level ground;

Step 2: Ensure that the drone is in a flat level and free from vibration;

Step 3: Click (Calibration) to start horizontal calibration;

Step 4: Re-power on the drone.

4.5. Compass calibration

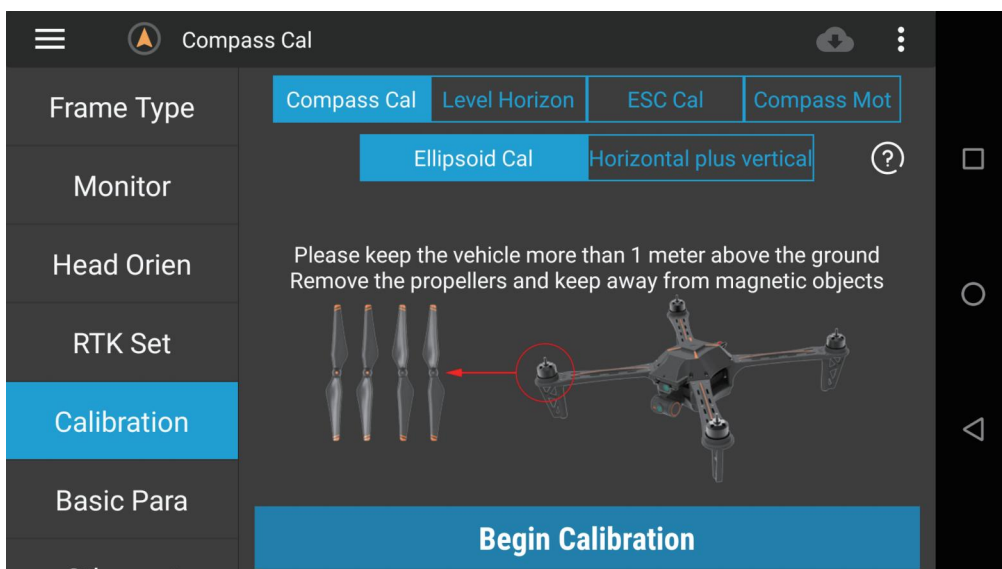

Perform ellipsoidal calibration and horizontal & vertical calibration on the drone (detailed information can be viewed by clicking on the “?”)

Note: When using the directional version, there is no need to calibrate the compass

4.6. ESC calibration

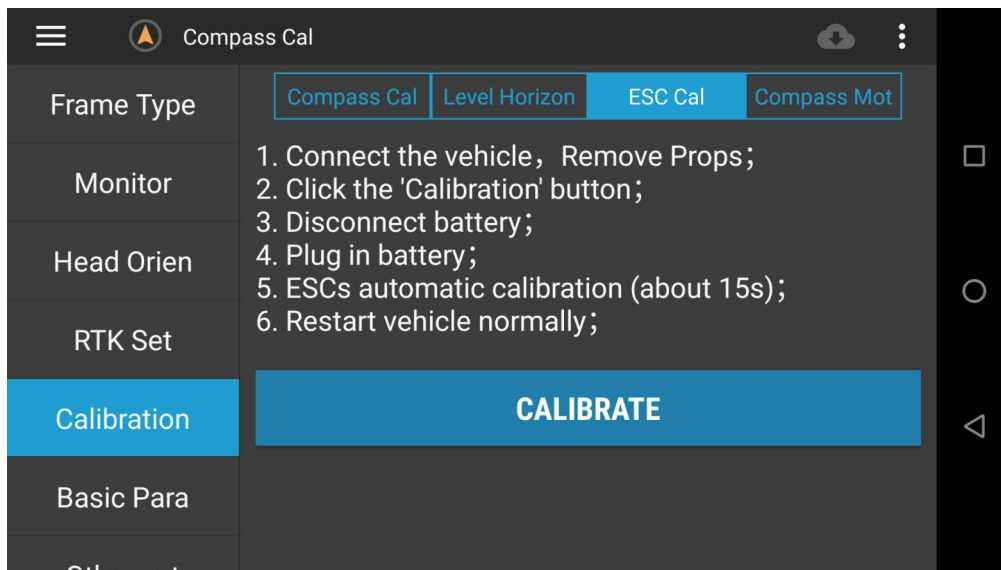

- Step 1: Connect the drone and remove the propeller from the it;
- Step 2: Click [Calibration];
- Step 3: Power off the drone;
- Step 4: Re-power on the battery;
- Step 5: The program will automatically calibrate the ESC (approximately 15 seconds);
- Step 6: Unplug and reinsert the battery to ensure normal use.

4.7. Motor testing

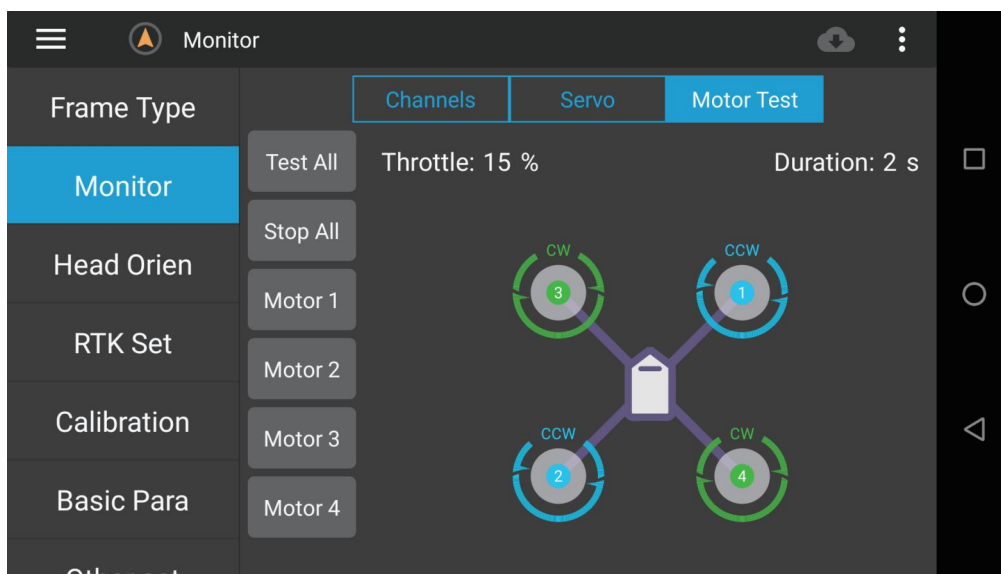

- Step 1: Enter the throttle value, preferably 5% -10% (for large drone motors with low KV values, it can be set higher);
- Step 2: Enter the duration in seconds;
- Step 3: Rotate according to the picture, test the motor number to see if the rotation direction is correct.

4.8、Basic Settings

4.8.1、Attitude Setting

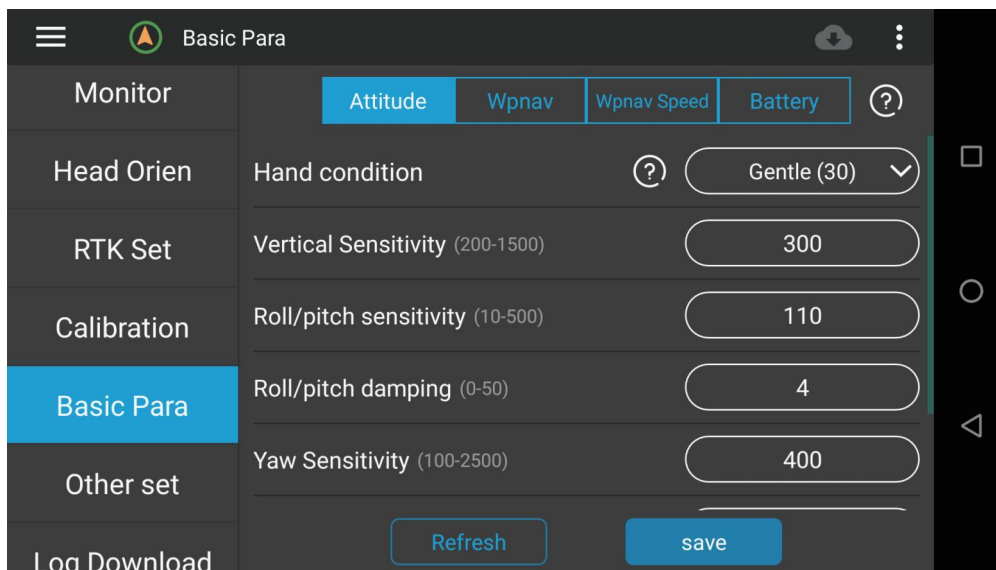

Adjust sensitivity and damping to improve the flight attitude of the drone. (For detailed information, click to “?” to check)

4.8.2、Navigation Settings

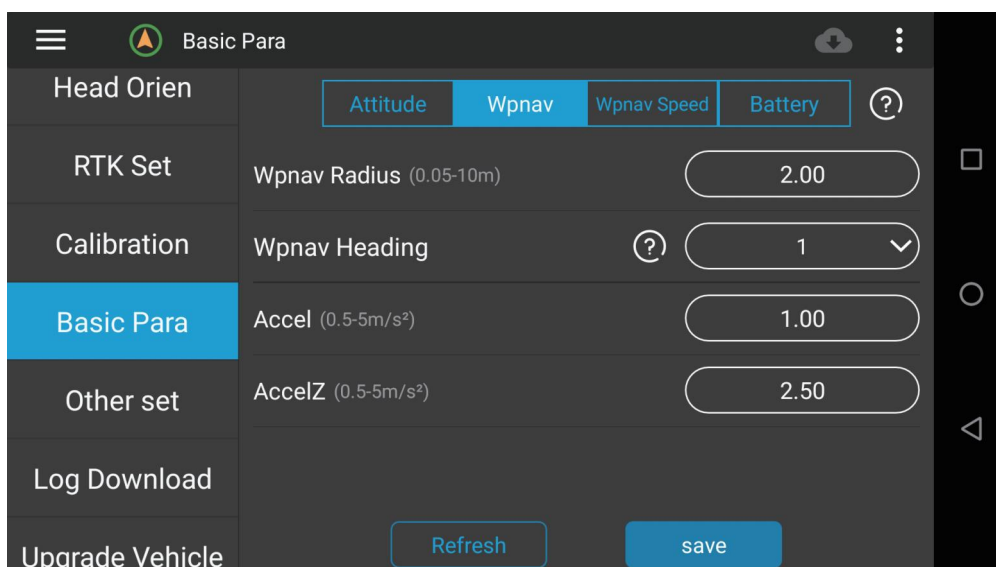

Set some parameters when executing route tasks or when the drone is in automatic mode. (For detailed information, click to “?” to check)

4.8.3、Speed Setting

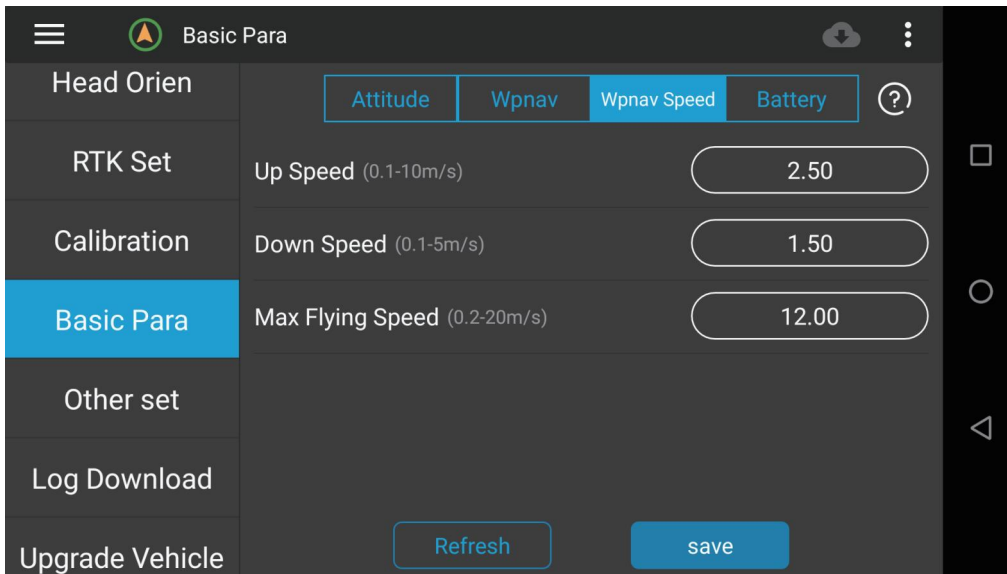

Adjust the flight speed of the drone. (For detailed information, click to “?” to check)

4.8.4、Power setting

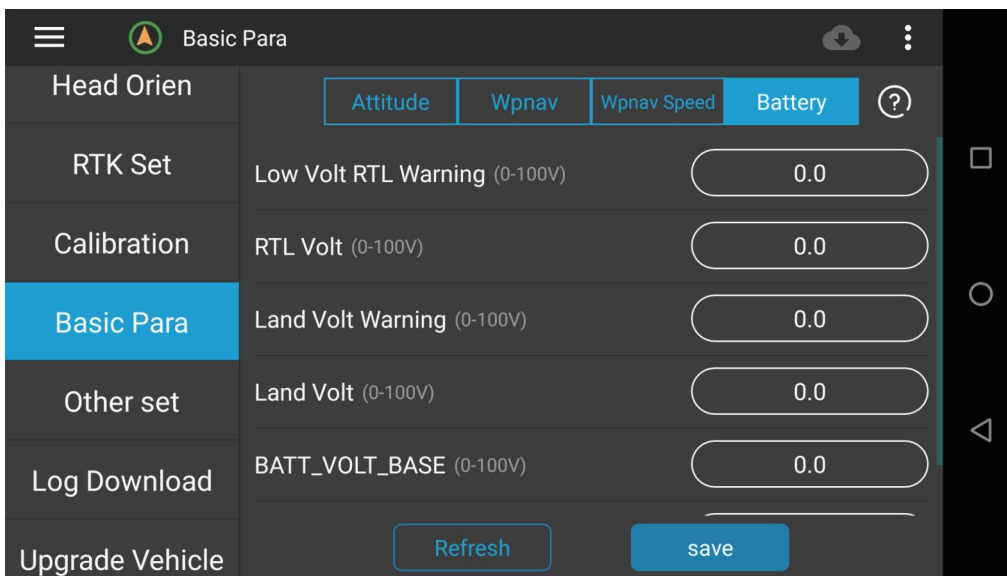

Low voltage return warning: When this voltage value is reached, the APP will send out a return warning sound.

Forced return voltage: When this voltage value is reached, the drone will forcibly return.

Forced landing voltage warning: When this voltage value is reached, the APP will send out a forced landing alarm.

Forced landing voltage: When this voltage value is reached, the drone will forcibly land off.

Unlocked compensation voltage: When the drone is powered on and remains unlocked, measure the current voltage of the battery with a multimeter, then check the voltage displayed in the data transmission and fill in the difference.

Full load compensation voltage: The drone needs to be fully loaded, hover for 20 seconds, and record the current voltage. Then lands immediately, wait for another 20 seconds, record the landing voltage, and fill in the difference.

Note: The specific voltage settings can be clicked to “?” for referring

4.9. Other Settings

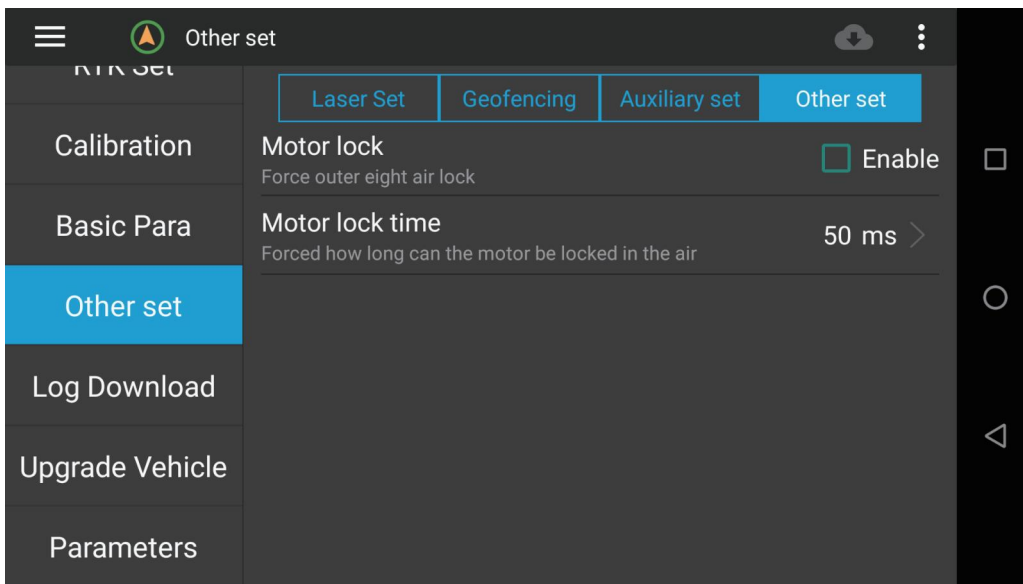

In other settings pages, you can set V mode to lock (Mode 2) and how long to be locked.

4.10. Auxiliary settings

1. First set the channel you need to control the servo in the H12 Tool App (H12 assistant), and set the fail-safe protection value. If the fail-safe protection value is 0, the current state means maintained.

The buttons on the remote control

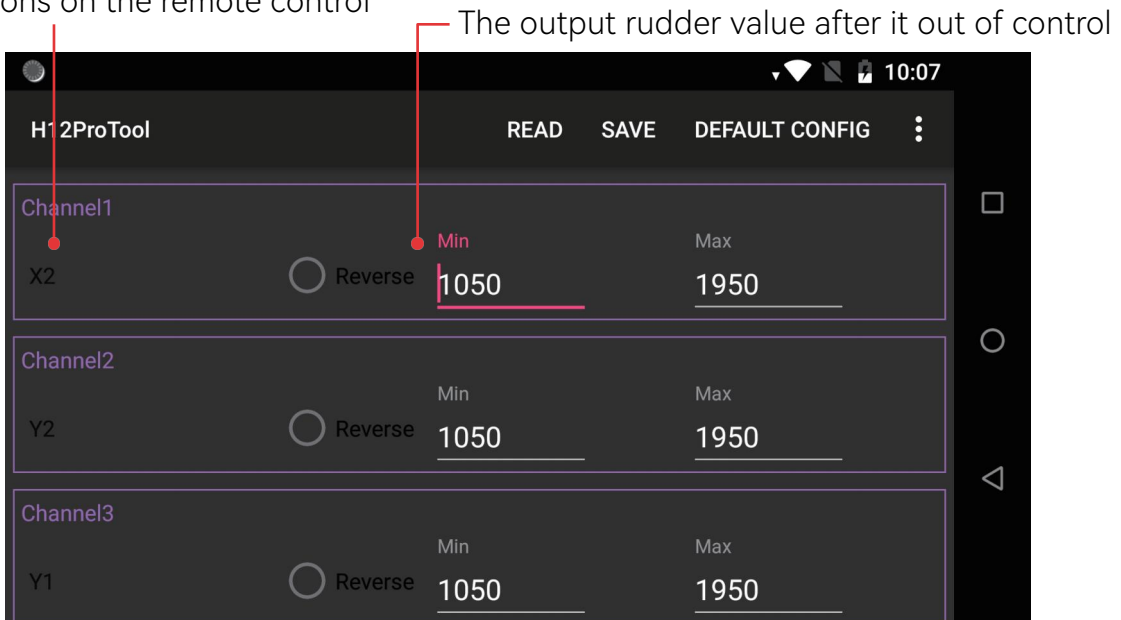

2. Connect the remote control to the flight control and open the flight control app: Skydroid Fly. Modify the desired channel in the flight control, entering password: 999-Auxiliary Settings.

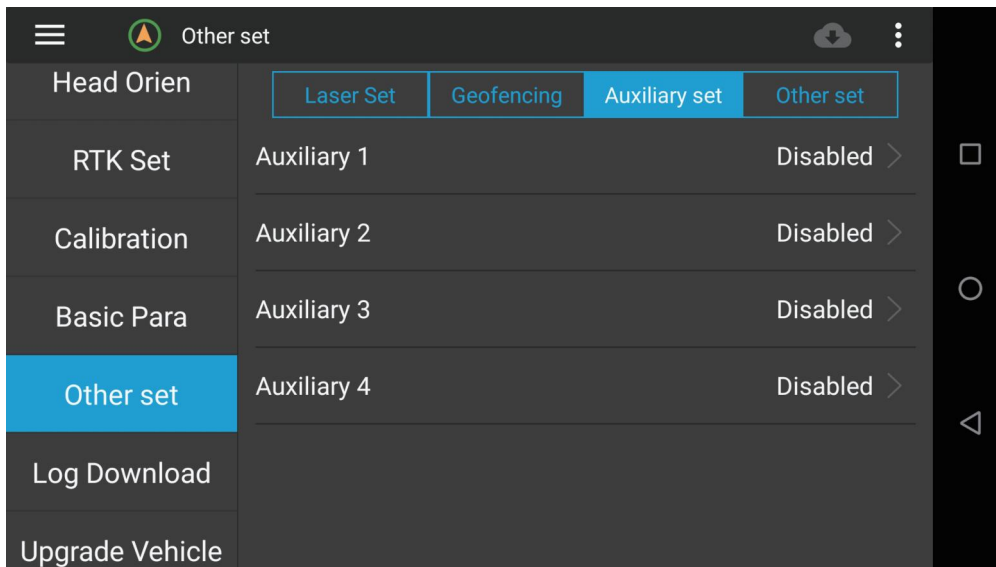

3.The loss of control protection of the servo can only be triggered after the drone is unlocked.

Test way: Unequipped the propellers on the drone, and after unlocking, turn off the remote control to test whether the servo is running or not.

4.11、Introduction of airplane modes

Flying mode (the flight controller will judge the GPS signal, please	Altitude fixed mode	When the GPS signal is poor or the compass is interfered, the drone will enter “Altitude Fixed Mode”, which only supports manual flying. In the fixed altitude mode, if the fixed point of the drone is abnormal, please land as soon as possible.
	GPS mode	Use GPS to achieve precise hovering and stable flying mode of
	Return Mode	When the drone is switched to the return position or loses control, the drone will climb to the return altitude and return

The flying mode is set by the three-position switch of the serial number ② of the remote control.serial number 2 of the remote control.

Flying speed	Low speed	Maximum speed 2m/s, ascending speed: 1.2m/s, descending speed 0.4m/s
	Medium speed	Maximum speed 12m/s, ascending speed: 4.2m/s, descending speed 2.0m/s
	High speed	The maximum speed is 17m/s, the ascending speed: 5.1m/s, the descending speed is 4.9m/s

*The flying speed can be changed in “Gear Settings” in the APP.

4.12、 Use of laser obstacle avoidance module

Laser obstacle avoidance function: only effective in drone return and automatic mode. When encountering obstacles, it stops moving forward, automatically climbs up, and after avoiding obstacles, it continues to move forward.

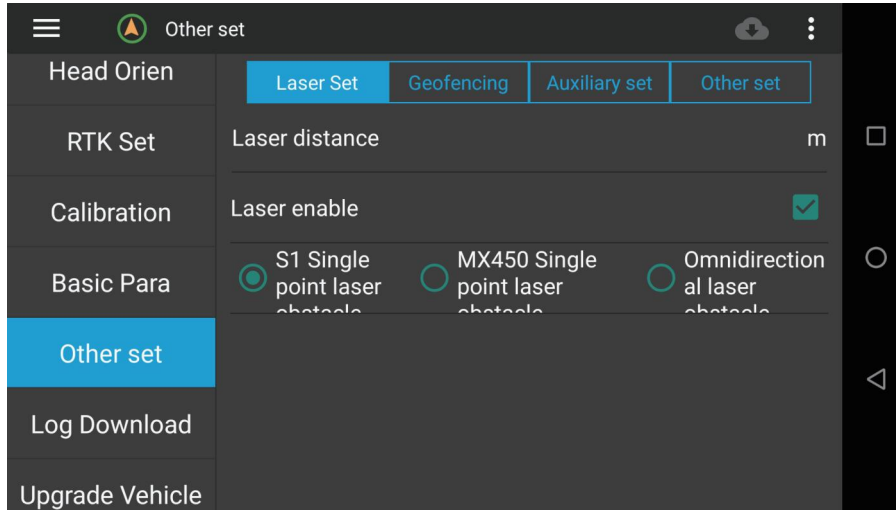

5、 Out of control protection

The return methods of the drone are RTL return, smart low battery return, and lost connection return. When taking off, GPS>12 pieces, the drone will successfully record the home point. If it is forced to take off without GPS signal, the latest GPS>12 piece position will be recorded as the home point.

Return process	<ol style="list-style-type: none"> 1. Record the home point 2. Trigger the return home condition 3. Adjust the direction of the nose 4. Return home based with the setting in the App <ol style="list-style-type: none"> (1) Ignore the current altitude of the drone, if the drone is within 5 meters of the horizontal distance, it will land directly. (2) If the drone is 5 meters away and within 20 meters, it will return at the current altitude, and the minimum return altitude is 5 meters. (3) At a distance of 20 meters, the drone will return directly above the return altitude. If the return altitude is less than the set return altitude, the drone will firstly ascending the return altitude and then, return home.
One key return	APP one key return home / remote control button one key return home
Return home with low batteryhome	<ol style="list-style-type: none"> 1. The drone will automatically return to home on low battery or according to its distance to the Home point. 2. If there is no GPS signal or weak signal when returning home with low battery, it will land automatically. 3. When taking off, if it is forced to take off when the GPS signal is not good, the drone will automatically return to the place where it got a good GPS signal for the first time. 4. If the power is less than 10% or the voltage is less than 11.1V, it will enter the landing mode.
Lost connection	<p>When the drone loses connection with the remote control for more than 2 seconds, it will return home automatically.</p> <p>Performance requirements:</p> <ol style="list-style-type: none"> (1) After the drone loses control for 2 seconds, it will trigger automatic return home; (2) In the process of losing connection and returning to home, if the drone is connected again, the drone will continue to perform the returning procedure; (3) Land directly when there is no GPS signal or the signal is not strong.

6、 Hardware installation

First of all you need to have a drone, here let's take the X-type quadcopter as an example, after you have a fully installed multicopter, please follow the steps below to install your S1-PRO.

(1) Install the S1-PRO on the drone, make sure it is installed in the center of the rack, and ensure that the installation position is horizontal, and the antenna is in the direction of the nose.

(2) Pair the remote controller, connect to Skydroid Fly, and do the previous calibration steps to calibrate your drone.

(3) Unlock the drone with joystick making as an inverted V. If the unlocking is normal, install the propellers and it can fly normally; if the unlocking is not normal, check the red fault prompt in the APP and solve it.

6.1、 Install S1-PRO on the drone

Mount the S1-PRO as close to the vehicle's gravity center as possible, using the foam provided. Make sure the flight controller is pointing forward.

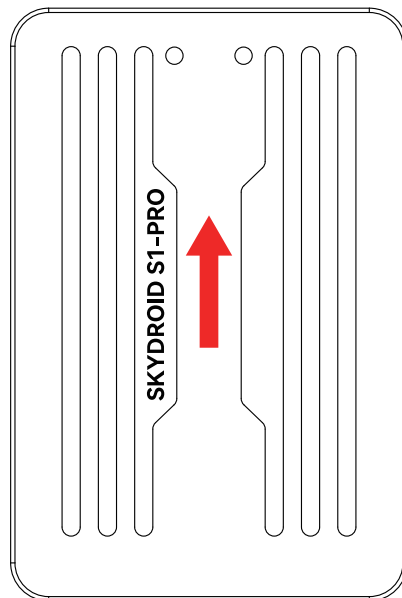

Install GPS, GPS can be regardless of direction, just calibrate the compass is OK.

6.2. Connect flight control to your multi axis system

6.2.1. Selection of motor steering sequence



CLOCKWISE ROTATION
USE PUSHER PROPELLER

Green CW rotates clockwise



COUNTER-CLOCKWISE ROTATION
USE NORMAL PROPELLER

Blue CCW rotates counterclockwise

Quadcopter

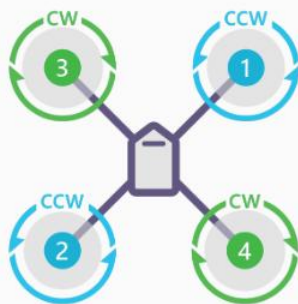

QAD X

Hexacopter

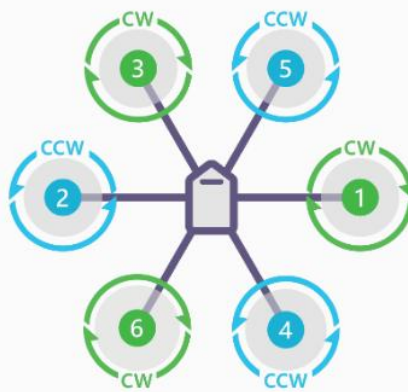

HEXA X

Octocopter

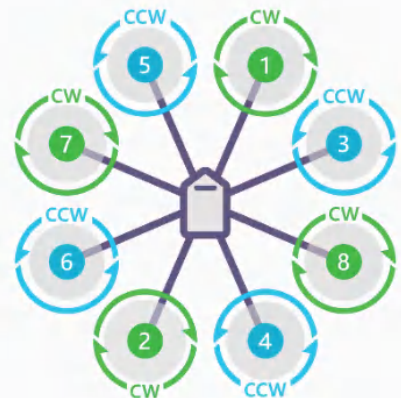

OCTO X

OctoQuad

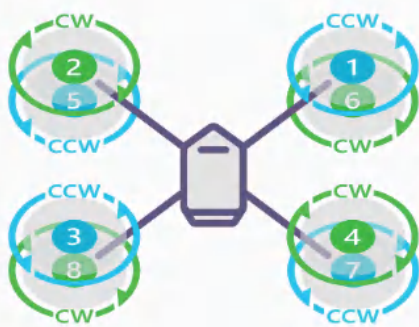

OCTO QUAD X8

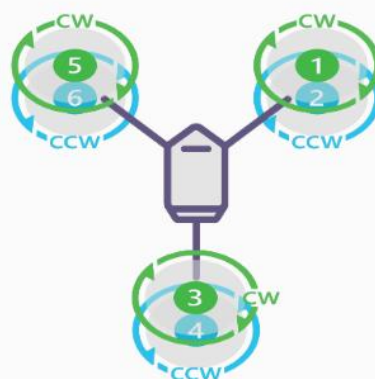

Y6B

Tricopter

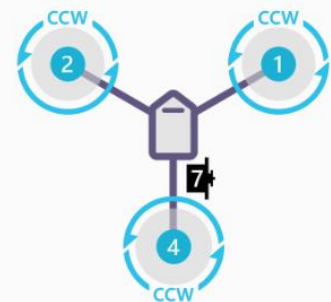

TRICOPTER

Note: Because the flight controller has no voltage output, the three-axis model drone needs to add BEC module pins to supply power to the servo.

6.2.2、 Identification of clockwise and counterclockwise propellers

Clockwise (called reverse propeller) and counterclockwise (called forward propeller). Thruster propellers are usually marked with a “P”. However not all propellers are marked, so both types can usually rotate in either direction. Therefore, it is more reliable to judge the propellers according to its shape. You can refer to these features to correctly identify the direction of the paddle.



6.2.3、 Accessory connection

The 3P cable of the obstacle avoidance dual-axis gimbal is inserted into the pin header on the far right, with the black line on top.

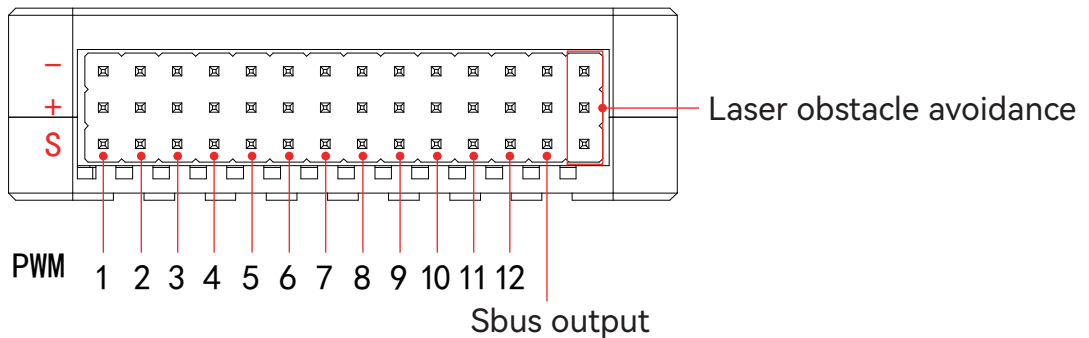

6.2.4、Installation of Webcam

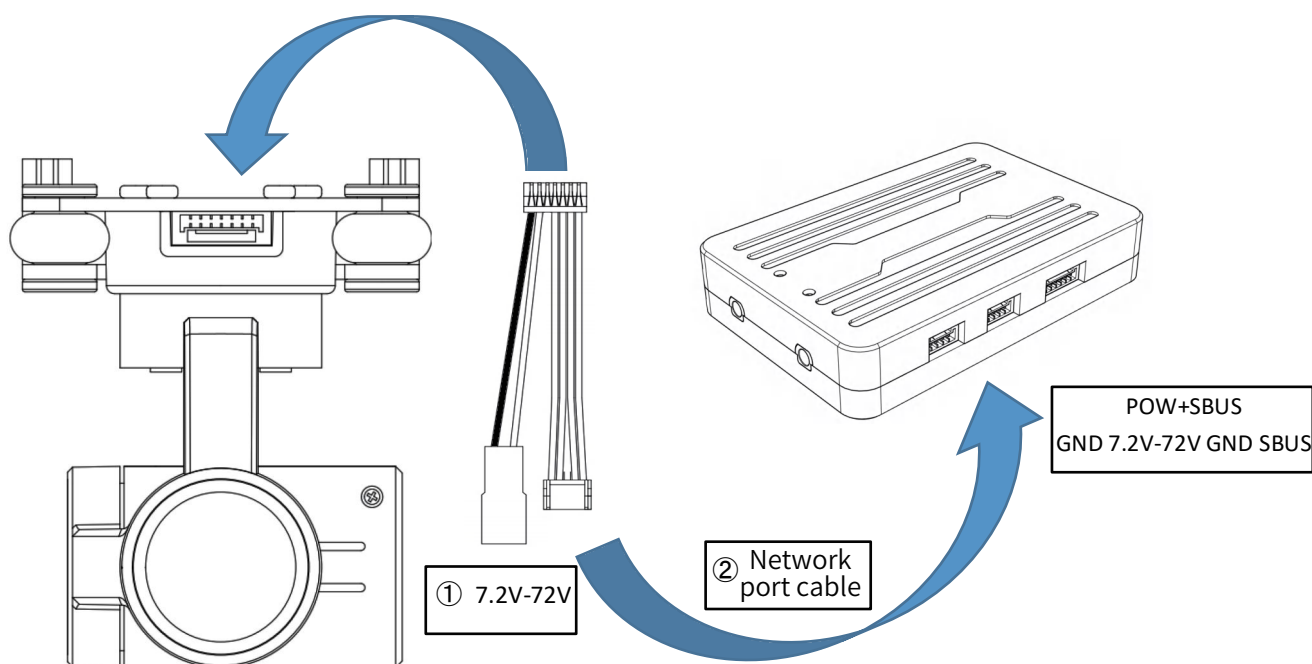

①Power cable	red JST-2P male plug, power supply: 7.2V~72V (DC power supply or lithium battery)	
②Network port cable (signal transmission length 50cm)	Network IP signal	RX -: network IP signal RX+: network IP signal TX-: network IP signal TX+: network IP signal
Video transmission	Network IP HD video output RTSP code stream rtsp://192.168.144.108:554/stream=0	
The storage card	C10 can currently support a Kingston Micro SD card with a maximum capacity of 64 GB. As the C10 requires fast reading and writing of 1080P video data, please use the standard Sandisk 16G memory card or purchase a Kingston 64G Class 10 Micro SD card to ensure normal video recording. Note: Please do not unplug the Micro SD card during the recording process, otherwise the video obtained during the shooting process may be lost.	

Note: The H12 Pro assistant needs to input the RTSP video stream address to display the camera contents

6.3、 Basic flying

1. Fully charge the battery before flying.
2. Put the drone on a flat and open ground with the user facing the tail of the drone (the battery tail plug is the tail of the drone).
3. Install the propeller correctly.

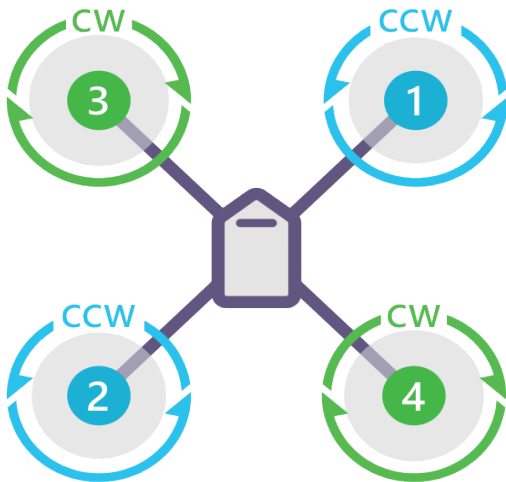

QUAD X

4. Turn on the remote control (long press the power button), and insert the battery plug into the power supply port of the drone.
5. Wait for the drone motor to make a long beep before the self-check succeeds.
6. Open the Skydroid Ground Station APP and click on the connection icon to connect to the video/image transmission. The GPS mode is recommended for take-off. It will search for satellites automatically, when the numbers of satellites more than 12 pieces, it can unlock and take-off.
7. Move the joystick upside-down “V” mode to unlock the drone, and slowly push the throttle joystick upward to let the drone take off smoothly.
8. If it is a big plane and it shakes, you need to adjust the sensitive in the app.
9. Pull down the throttle stick to land the drone.
10. After landing, pull the throttle stick to the lowest position and hold it for more than 3 seconds until the motor stops.
11. Plug out the drone battery from the drone tail and the power of the remote controller in turn after stopping.

6.4、Geo-fence

The Geo-fence is turned off default. If necessary, it can be turned on in flight control and dispatching parameter.

This is a security protection mechanism that protects the drone from flying out of the range you set. Enabling this mechanism will detect whether GPS is positioned, and it cannot be unlocked without positioning.

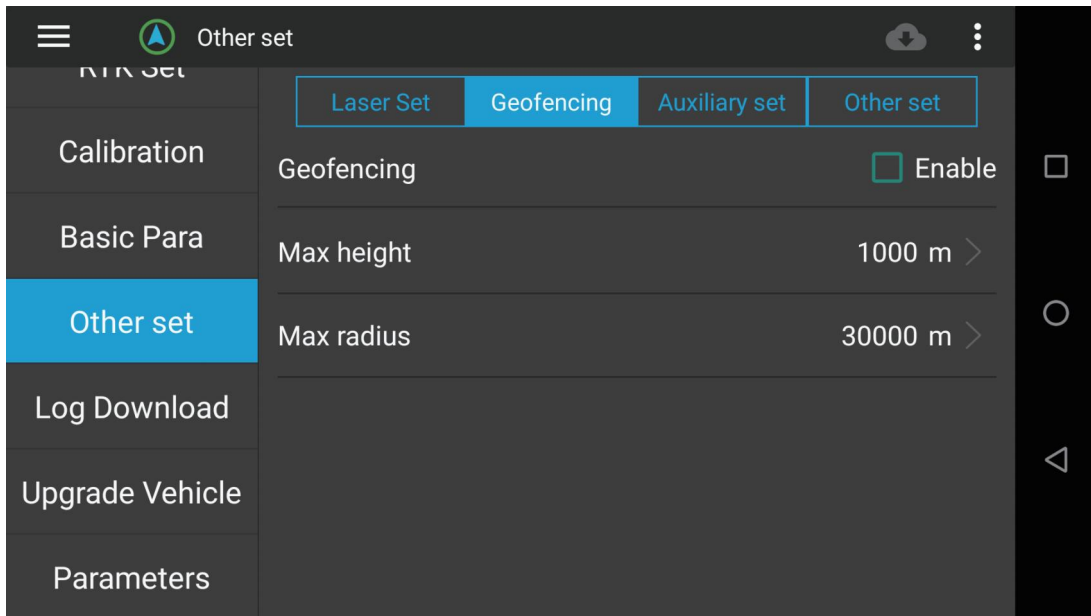

7、Log download and checking

Check flight records in Skydroid Fly app.

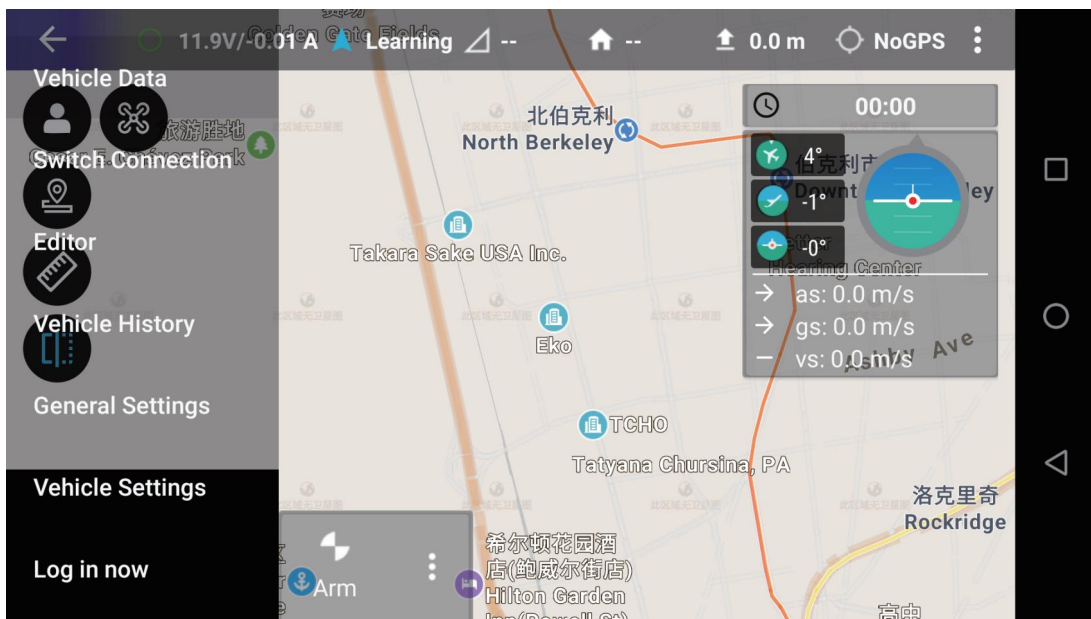

8、FAQ

1.The remote control cannot be connected.

①Check whether the APP type is correct.

②Whether the background occupies the Skydroid Fly APP or not.

2.The image is stuck and disconnected

①Adjust the angle of the antenna to aim at the drone, and there should be no obstruction in the middle.

②Change the flying field, do not fly near tall buildings or signal towers.

3.Unsteady hovering of the drone

①Change the flying field, do not fly near tall buildings or signal towers.

②Carry out drone compass calibration and level calibration.

③check whether the wind is too strong to affect the flight.

④Fine-tuning the sensitivity.

4.The GPS accuracy of the drone is inaccurate or cannot pass the GPS accuracy test.

①Search for at least 11 GPS in an open outdoor place.

5.Unclear shooting.

①Check if the protective film of the lens is removed.

②whether use in a good light environment.

6.The lens is hazy and foggy.

①The humid climate causes the lens to fog, change the storage location of the drone.

②Place desiccant when storing.

7.Lost pictures or videos taken.

When finish recording, please remember to click the “recording” icon to stop recording, otherwise the video may be damaged or lost.

Exemptions

When using this product, Skydroid shall not be liable for compensation and legal responsibility for direct or indirect damage caused by the following reasons.

1. The user has caused damage when drinking, taking drugs, drug anesthesia, dizziness, fatigue, nausea and other poor physical or mental conditions.
2. Personal injury, property damage and legal liability caused by the user's subjective intention or misjudgment.
3. Compensation for any mental damage caused by the accident.
4. Damage caused by the user flying in a flight area prohibited by laws and regulations such as nature reserves.
5. Other damages caused by self-modification or replacement of accessories or parts not produced by Skydroid, resulting in poor operation of the drone.
6. The drone's natural wear and tear (flying time of 100 hours or more), decay, and aging of the wiring have caused the aircraft itself to operate poorly.
7. The drone issued a low-voltage alarm and did not land, causing the drone to fall or crash.
8. Knowing that the drone is in an abnormal state (such as water, oil, soil, sand and other unidentified substances, incomplete assembly, obvious failure of main components, obvious defects or missing parts), damage caused by forced flying.
9. The drone is in a magnetic field interference zone, a radio interference zone (such as near high-voltage power lines, large power equipment, radio and television transmission towers, mobile phone base stations, etc.), a no-fly zone specified by the government, or the user's field of view is in backlight, blocked by obstacles, caused by flying under conditions that are not suitable for control, such as blur, poor eyesight, and other conditions that are not suitable for control.
10. Flying in bad weather, such as rainy or windy (more than level 4), snow, hail and other bad weather.
11. The drone has encountered collisions, overturns, fires, explosions, lightning strikes, storms, tornadoes, rainstorms, floods, tsunamis, subsidence, ice sinks, cliffs, avalanches, hailstorms, mudslides, landslides, earthquakes, etc.
12. Any data, audio or image data obtained by the user using the drone is damaged due to infringement.
13. Regarding the battery, such as damage caused by the matching or improper use of the protection circuit, battery pack, and charger.
14. Any indirect losses and legal liabilities caused by problems with equipment or accessories (including memory cards), such as images or videos that cannot be saved.
15. The loss and legal liability caused by the user recklessly flying unsafe without completing sufficient flying training.
16. The user fails to comply with the use methods and various precautions mentioned in the user manual or user quick start guide of Skydroid official website and the loss and legal responsibility caused by various precautions.
17. Other damages that are not within the scope of Skydroid liability.

Suggestions

1.This product is compatible with the external environment and meets the FCC's limited requirements for wireless video.

This product complies with FCC Part 15 regulations, which contains two aspects:

(1)The work of the product will not cause harmful interference to others;

(2)At the same time, the product can withstand harmful interference that may cause the product to work abnormally.

Attentions: The manufacturer is not responsible for any wireless and other interference caused by illegal modifications and changes to the equipment. Because these modifications and changes have exceeded the user's operating authority.

Attentions: This product has passed tests and has been proven to comply with the FCC Part 15 requirements for Class B digital products.

These regulations are to ensure that the product will not cause harmful effects on the residential environment when it is installed and used. This product will radiate radio frequency energy when it is working. If the product is not installed and used in accordance with the instructions, it may cause interference to public wireless communication. However, in some specific installation and use occasions, there is no guarantee that interference will not occur. The user can check whether some interference is caused by this product by turning on and off the product. If this product has indeed caused interference to wireless and video receiving equipment, users can try to take the following corrective measures:

√ Properly adjust the position of the antenna.

√ Increase the distance between the product and the receiving device.

√ Asking for help from dealers or experienced wireless/video technicians.

2.When using this product, make sure that the product antenna is not less than 20cm away from people. The USB interface inside the remote controller and the USB interface of the drone can only be connected with the communication interface USB2.0 or above. It is forbidden to connect to the USB power interface. Please choose the correct type of battery. Using other types of batteries may cause explosion. At the same time, please follow the instructions to properly dispose of the used battery.

Therefore, we Skydroid promises that this product meets the basic requirements specified in 19991/EC and some other related directive requirements.

3.This product is for personal use only, and it is strictly forbidden to use this product for any behavior that violates international and local laws and regulations.

Do not use this product for the following activities (only examples, not limited to this):

(1) Defame, abuse, harass, stalk, threaten or other violate the legal rights of others (such as the right of privacy and publicity);

(2) Taking pictures of others or private areas without permission;

(3) Use this product for illegal or inappropriate purposes other than general commercial purposes (such as spying, military activities, or unauthorized inspections and investigations, etc.);

(4) Violate any laws, administrative regulations and related social customs in the area where this product is used.

Attentions:

(1) In some cases, shooting or recording performances, exhibitions or other commercial buildings for private purposes may also cause infringement of the intellectual property rights of others;

(2) In some regions and countries, small aerial models are also prohibited from participating in any commercial activities.

If you encounter an unsolvable problem during the installation process, please contact Skydroid officially authorized agents or Skydroid technical support. The intellectual property rights of this product and manual are owned by Skydroid Co., Ltd. Without written permission, no organization or individual may reproduce, copy and publish in any form. If quoted or published, the source should be indicated as Skydroid Co., Ltd., and the manual should not be quoted contrary to the original intent.

Reminder: Please read the user manual carefully before use!

- Always be supervised while charging
- Please unplug the charging cable immediately after charging
- Propeller components may cause injury
- This product is not a toy
- Not suitable for children under 14 years



WeChat public account

Skydroid National Service Hotline
400-6996-520

Product name: S1-PRO

Manufacturer: Skydroid Co., Ltd

Address: 2nd Floor, Building A, Haixi Yucheng Base, High-tech Industrial Park, Quanzhou City, Fujian China.

Email: sales01@skydroid.xin

Official Website: www.skydroid.xin